

MSP430 WORKSHOP

A Simple Digital Voltmeter

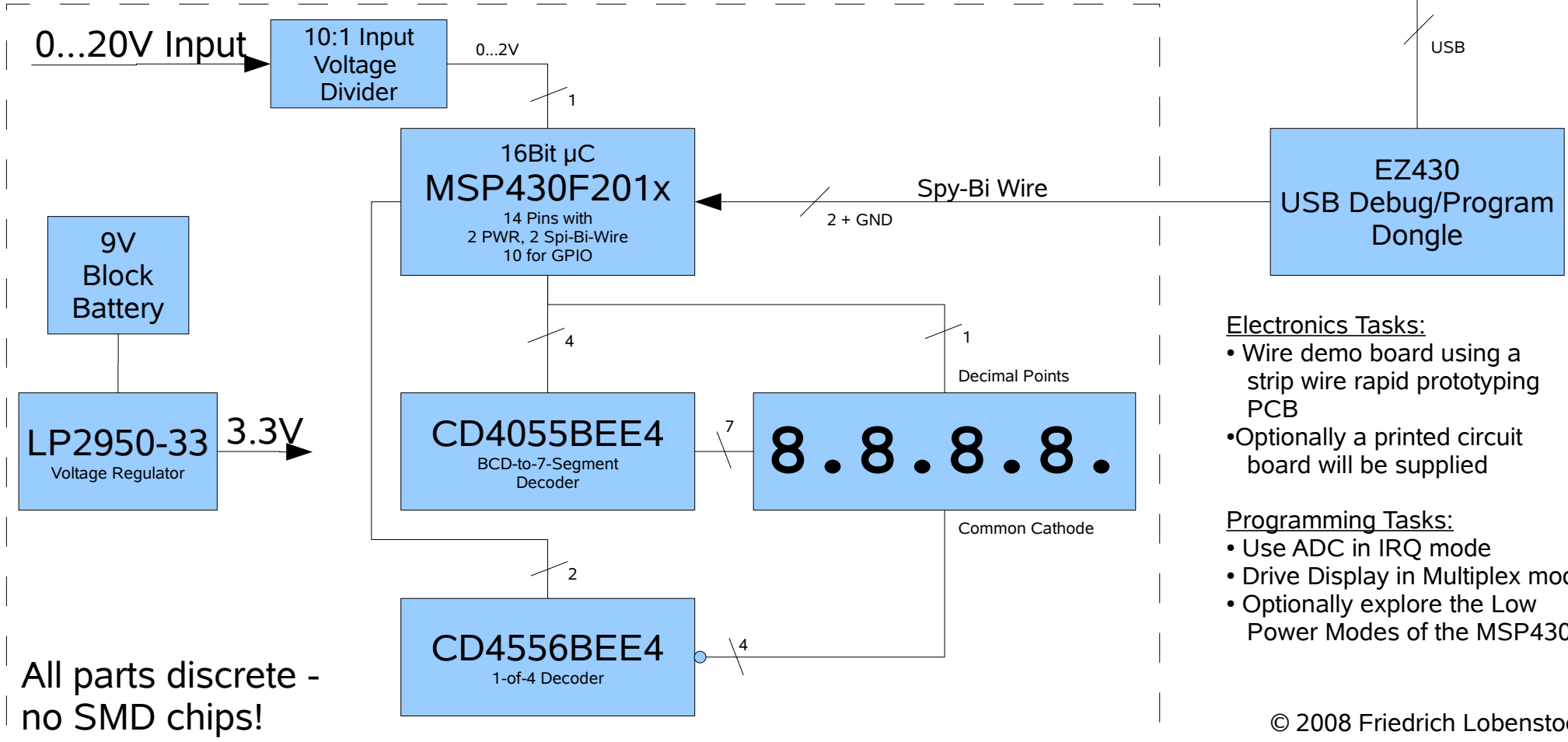
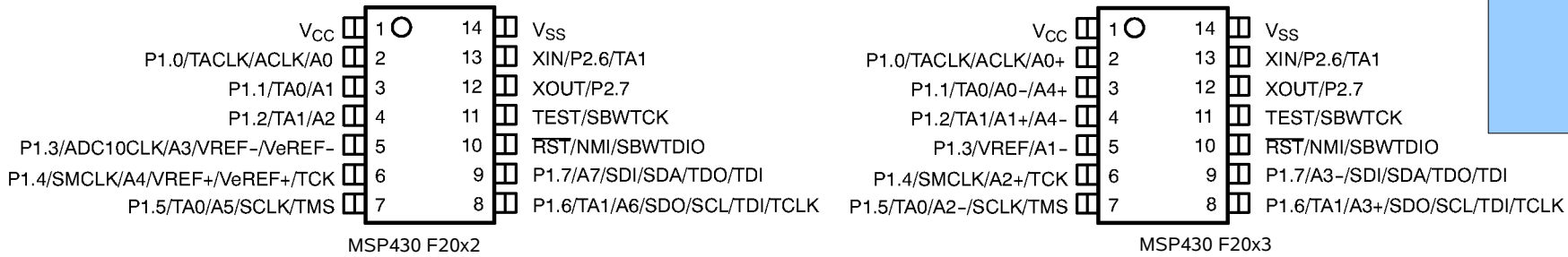

All parts discrete - no SMD chips!

- Electronics Tasks:**
- Wire demo board using a strip wire rapid prototyping PCB
 - Optionally a printed circuit board will be supplied
- Programming Tasks:**
- Use ADC in IRQ mode
 - Drive Display in Multiplex mode
 - Optionally explore the Low Power Modes of the MSP430